

# BOARD QUESTION PAPER: NOVEMBER 2020

## Maths - II

**Time: 2 Hours**

**Max. Marks: 40**

**Notes:**

- i. All questions are compulsory.
- ii. Use of calculator is not allowed.
- iii. The numbers to the right of the questions indicate full marks.
- iv. In case of MCQ's [Q. No. 1(A)] only the first attempt will be evaluated and will be given credit.
- v. For every MCQ, the correct alternative (A), (B), (C) or (D) with sub-question number is to be written as an answer.
- vi. Draw proper figures for answers wherever necessary.
- vii. The marks of construction should be clear. Do not erase them.
- viii. Diagram is essential for writing the proof of the theorem.

**Q.1. (A) For each of the following sub-question four alternative answers are given. Choose the correct alternative and write its alphabet: [4]**

1.  $\triangle ABC \sim \triangle PQR$  and  $\angle A = 45^\circ$ ,  $\angle Q = 87^\circ$ , then  $\angle C =$  \_\_\_\_\_.  
 (A)  $45^\circ$  (B)  $87^\circ$  (C)  $48^\circ$  (D)  $90^\circ$
2.  $\angle PRQ$  is inscribed in the arc  $PRQ$  of a circle with centre 'O'.  
 If  $\angle PRQ = 75^\circ$ , then  $m(\text{arc } PRQ) =$  \_\_\_\_\_.  
 (A)  $75^\circ$  (B)  $150^\circ$  (C)  $285^\circ$  (D)  $210^\circ$
3. A line makes an angle of  $60^\circ$  with the positive direction of X-axis, so the slope of a line is \_\_\_\_\_.  
 (A)  $\frac{1}{2}$  (B)  $\frac{\sqrt{3}}{2}$  (C)  $\sqrt{3}$  (D)  $\frac{1}{\sqrt{3}}$
4. Radius of a sector of a circle is 5 cm and length of arc is 10 cm, then the area of a sector is \_\_\_\_\_.  
 (A)  $50 \text{ cm}^2$  (B)  $25 \text{ cm}^2$  (C)  $25 \text{ m}^2$  (D)  $10 \text{ cm}^2$

**(B) Solve the following sub-questions: [4]**

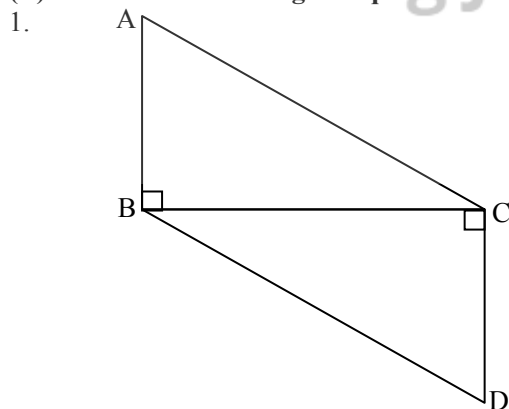

In the above figure, seg  $AB \perp$  seg  $BC$  and seg  $DC \perp$  seg  $BC$ .

If  $AB = 3 \text{ cm}$  and  $CD = 4 \text{ cm}$ , then find  $\frac{A(\triangle ABC)}{A(\triangle DCB)}$ .

2. In cyclic  $\square ABCD$ ,  $\angle B = 75^\circ$ , then find  $\angle D$ .
3. Point A, B, C are collinear. If slope of line AB is  $-\frac{1}{2}$ , then find the slope of line BC.
4. If  $3 \sin \theta = 4 \cos \theta$ , then find the value of  $\tan \theta$ .

Q.2. (A) Complete the following activities and rewrite it (Any two):

1.

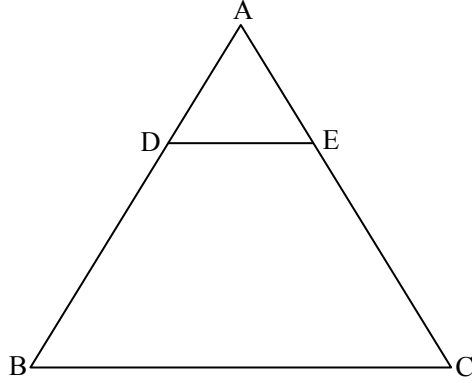

In  $\triangle ABC$ , seg  $DE \parallel$  side  $BC$ . If  $AD = 6$  cm,  $DB = 9$  cm,  $EC = 7.5$  cm, then complete the following activity to find  $AE$ .

**Activity:** In  $\triangle ABC$ , seg  $DE \parallel$  side  $BC$  ..... (given)

$$\therefore \frac{AD}{DB} = \frac{AE}{EC} \dots\dots \square$$

$$\therefore \frac{6}{9} = \frac{AE}{\square}$$

$$\therefore AE = \frac{6 \times 7.5}{\square}$$

$$\therefore AE = \square$$

2.

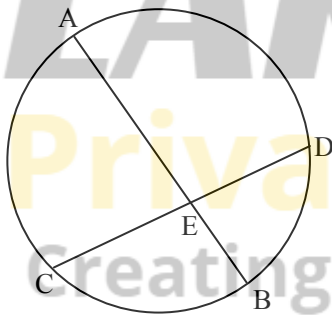

In the above figure, chord  $AB$  and chord  $CD$  intersect each other at point  $E$ . If  $AE = 15$ ,  $EB = 6$ ,  $CE = 12$ , then complete the activity to find  $ED$ .

**Activity:**

Chord  $AB$  and chord  $CD$  intersect each other at point  $E$  ..... (given)

$$\therefore CE \times ED = AE \times EB \dots\dots \square$$

$$\therefore \square \times ED = 15 \times 6$$

$$\therefore ED = \frac{\square}{12}$$

$$\therefore ED = \square$$

3. If  $C(3, 5)$  and  $D(-2, -3)$ , then complete the following activity to find the distance between points  $C$  and  $D$ .

**Activity:**

Let  $C(3, 5) \equiv (x_1, y_1)$ ,  $D(-2, -3) \equiv (x_2, y_2)$

$$CD = \sqrt{(x_2 - \square)^2 + (y_2 - y_1)^2} \dots\dots \text{(formula)}$$

$$\therefore CD = \sqrt{(-2 - \square)^2 + (-3 - 5)^2}$$

$$\therefore CD = \sqrt{\square + 64}$$

$$\therefore CD = \sqrt{\square}$$

**B. Solve the following sub-questions (Any four):**

[8]

1.  $\triangle ABC \sim \triangle PQR$ ,  $A(\triangle ABC) = 81 \text{ cm}^2$ ,  $A(\triangle PQR) = 121 \text{ cm}^2$ .  
If  $BC = 6.3 \text{ cm}$ , then find  $QR$ .
2. In  $\triangle PQR$ ,  $\angle P = 60^\circ$ ,  $\angle Q = 90^\circ$  and  $QR = 6\sqrt{3} \text{ cm}$ , then find the values of  $PR$  and  $PQ$ .
3. Find the slope of a line passing through the points  $A(2, 5)$  and  $B(4, -1)$ .
4. Draw a circle with centre 'O' and radius 3.2 cm. Draw a tangent to the circle at any point P on it.
5. Find the surface area of a sphere of radius 7 cm.

**Q.3. A. Complete the following activities and rewrite it (Any one):**

[3]

1.

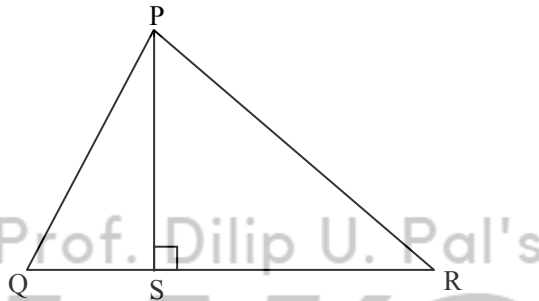

In  $\triangle PQR$ , seg  $PS \perp$  side  $QR$ , then complete the activity to prove  $PQ^2 + RS^2 = PR^2 + QS^2$ .

**Activity:**

In  $\triangle PSQ$ ,  $\angle PSQ = 90^\circ$   
 $\therefore PS^2 + QS^2 = PQ^2$  ..... (Pythagoras theorem)  
 $\therefore PS^2 = PQ^2 - \square$  ..... (I)

Similarly,

In  $\triangle PSR$ ,  $\angle PSR = 90^\circ$   
 $\therefore PS^2 + \square = PR^2$  ..... (Pythagoras theorem)  
 $\therefore PS^2 = PR^2 - \square$  ..... (II)  
 $\therefore PQ^2 - \square = \square - RS^2$  ..... from (I) and (II)  
 $\therefore PQ^2 + \square = PR^2 + QS^2$

2. Measure of arc of a circle is  $36^\circ$  and its length is 176 cm. Then complete the following activity to find the radius of circle.

**Activity:**

Here, measure of arc  $= \theta = 36^\circ$   
 Length of arc  $= l = 176 \text{ cm}$

$$\therefore \text{Length of arc } (l) = \frac{\theta}{360} \times \square \text{ ..... (formula)}$$

$$\therefore \square = \frac{36}{360} \times 2 \times \frac{22}{7} \times r$$

$$\therefore 176 = \frac{1}{\square} \times \frac{44}{7} \times r$$

$$\therefore r = \frac{176 \times \square}{44}$$

$$\therefore r = \square \times 70$$

Radius of circle  $(r) = \square \text{ cm}$

**B. Solve the following sub-questions (Any two):**

[6]

1. Prove that, "The ratio of the intercepts made on a transversal by three parallel lines is equal to the ratio of the corresponding intercepts made on any other transversal by the same parallel lines."
2. Draw a circle with centre 'O' and radius 3.4 cm. Draw a chord MN of length 5.7 cm in it. Construct tangents at points M and N to the circle.
3. Prove that:  

$$\frac{1}{\sec\theta - \tan\theta} = \sec\theta + \tan\theta.$$
4. Radii of the top and base of frustum are 14 cm and 8 cm respectively. Its height is 8 cm. Find its curved surface area. ( $\pi = 3.14$ )

**Q.4. Solve the following sub-questions (Any two):**

[8]

1.

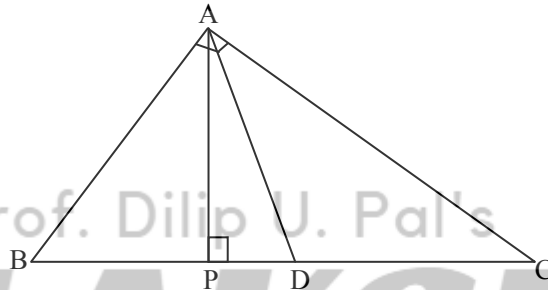

In  $\triangle ABC$ ,  $\angle BAC = 90^\circ$ , seg  $AP \perp$  side  $BC$ ,  $B-P-C$ . Point  $D$  is the mid-point of side  $BC$ , then prove that  $2AD^2 = BD^2 + CD^2$ .

2.

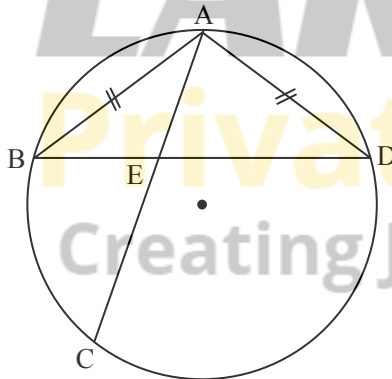

In the above figure, chord  $AB \cong$  chord  $AD$ . Chord  $AC$  and chord  $BD$  intersect each other at point  $E$ . Then prove that:  
 $AB^2 = AE \times AC$ .

3. A straight road leads to the foot of the tower of height 48 m. From the top of the tower the angles of depression of two cars standing on the road are  $30^\circ$  and  $60^\circ$  respectively. Find the distance between the two cars. ( $\sqrt{3} = 1.73$ )

**Q.5. Solve the following sub-questions (Any one):**

[3]

- i. Let  $M$  be a point of contact of two internally touching circles. Let line  $AMB$  be their common tangent. The chord  $CD$  of the bigger circle touches the smaller circle at point  $N$ . The chord  $CM$  and chord  $DM$  of bigger circle intersect the smaller circle at point  $P$  and  $R$  respectively.
  - a. From the above information draw the suitable figure.
  - b. Draw seg  $NR$  and seg  $NM$  and write the two pairs of congruent angles in smaller circle considering tangent and chord.
  - c. By using the property which is used in (b) write the two pairs of congruent angles in the bigger circle.
- ii. Draw a circle with centre 'O' and radius 3 cm. Draw a tangent segment  $PA$  having length  $\sqrt{40}$  cm from an exterior point  $P$ .